

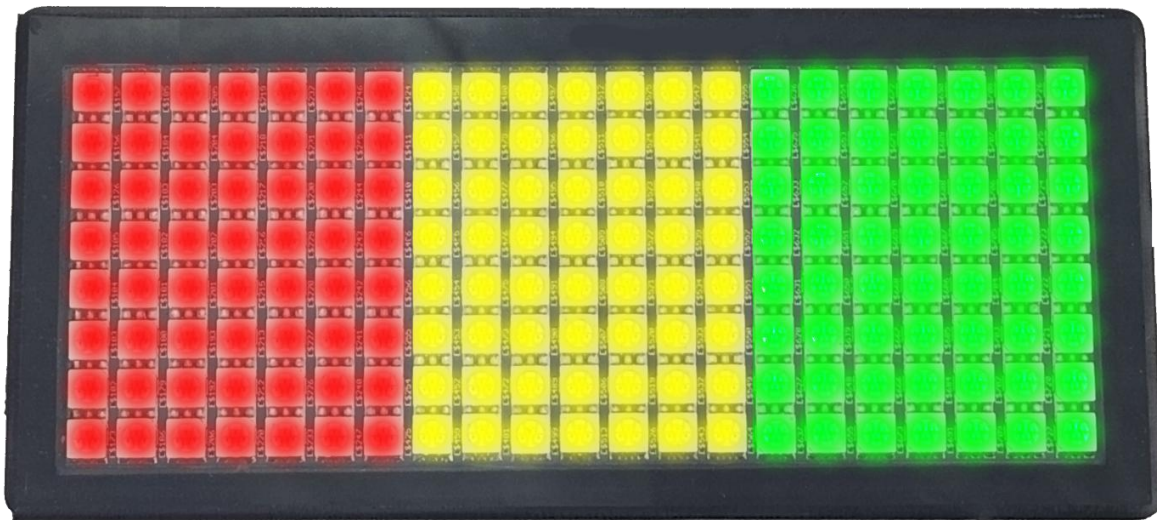

Wireless Process Indicator

Model: TFL300



Installation and User Manual

Revision 01 – October 2023

© CASWA Pty Ltd – 2018



CONTENTS

1	OVERVIEW.....	3
1.1	Product Description	3
2	SPECIFICATIONS.....	4
2.1	Physical Specifications	4
2.2	Electrical Specifications.....	4
3	INSTALLATION DETAILS	5
3.1	Wiring Diagrams.....	6
4	COMMISSIONING DETAILS	6
4.1	Installing and Launching the FSU Application	6
4.1.1	FSU Program Installation.....	6
4.1.2	Installing the FSU application.....	6
4.1.3	Launching the application	6
4.2	Connecting to the Device.....	7
4.3	Managing Firmware	8
4.4	TFL300 Configuration	10
4.4.1	Standard TFL300 Configuration	10
	APPENDIX A: FSU SYSTEM REQUIREMENTS.....	10



1 OVERVIEW

Take the pain out of installing traffic lights with TFL300 with just two wires and two screws you can add an inexpensive electronic load indicator that's quick, easy and safe to set up.

1.1 Product Description

TFL300 works by connecting wirelessly to any HoistNet device and changing and using bright coloured LEDs to indicate the load, pressure, windspeed that the remote device is measuring. You can set the thresholds for the changes independently of the settings on the remote device.

For example, if you had a 10T crane with a LiftlogDX data logger or HB200 load display, you could set up the TFL300 as shown in Figure 1.

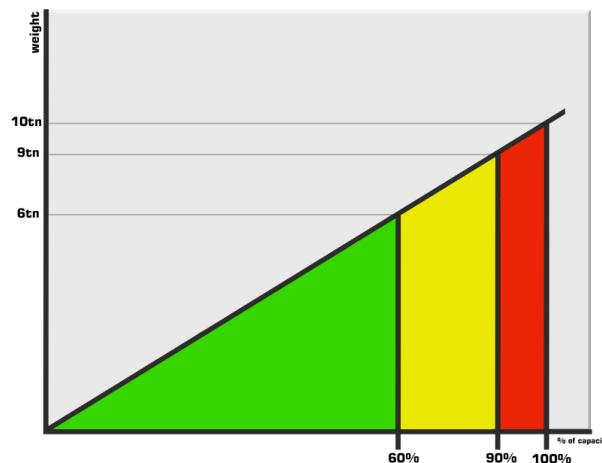

Figure 1: TFL300 Threshold Example



2 SPECIFICATIONS

2.1 Physical Specifications

Overall length (mm):	150.5mm
Overall width (mm):	75mm
Overall height (mm):	91mm
Weight (kg):	0.3
Mounting:	Supplied bracket, 4x6mm holes

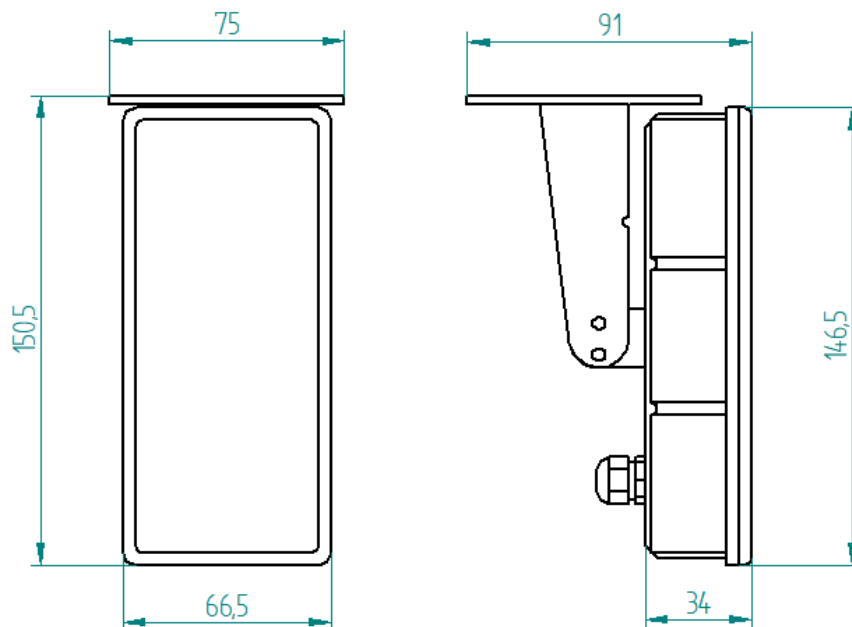

2.2 Electrical Specifications

Parameter	Description	Min	Typ	Max	Units
V_{in}	Supply voltage	32		250	VAC
I	Current consumption	25		200	mA
T	Allowable operating temperature	-20		85 ^{Note1}	°C

Note1: Extended operation at maximum temperature may reduce the life of the device.



3 INSTALLATION DETAILS

Mount the bracket using 2-4 6mm screws in the base.

Loosen the two 4mm bolts in the pivot of the bracket to adjust the angle of the display.

Loosen the two 5mm bolts in the rear mounting plate to adjust the rotation of the display

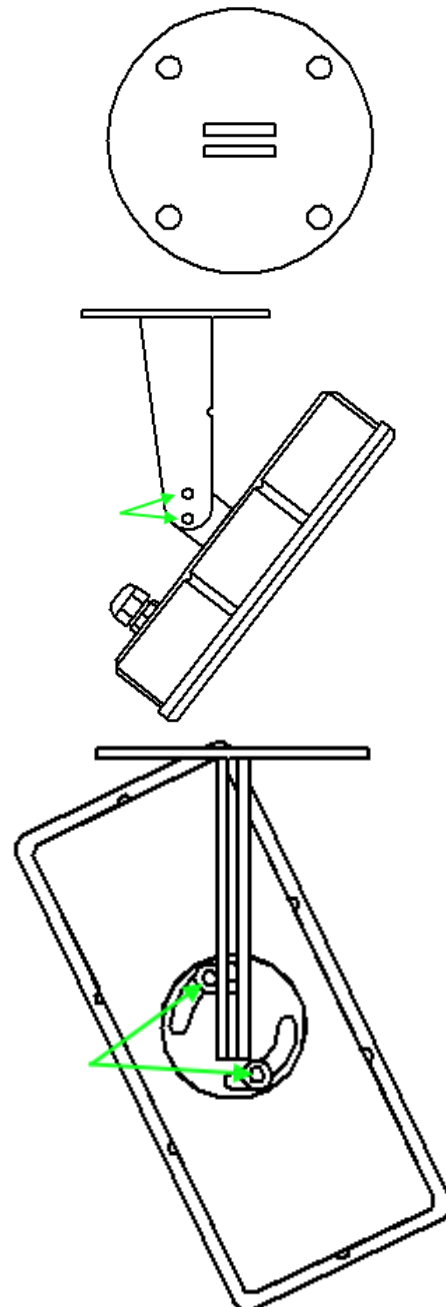



3.1 Wiring Diagrams

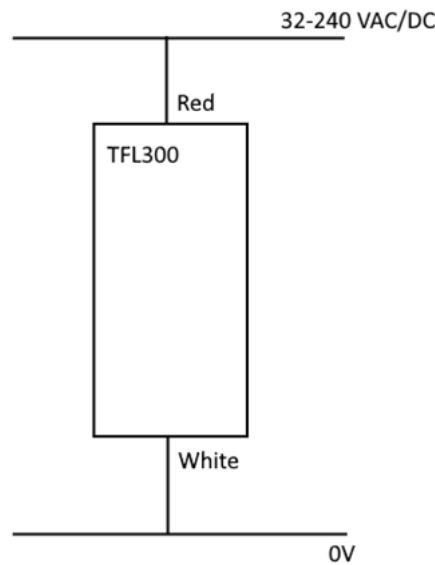

Figure 2: Connecting to Liftlog or Maxout

4 COMMISSIONING DETAILS

Like all SoleDigital products, the TFL300 is configured by the Field Service Utility.

4.1 Installing and Launching the FSU Application

4.1.1 FSU Program Installation

Ensure that your computer is switched on, and connected to the internet and that the minimum required software versions are installed. Ensure that the LINK-2 modem is inserted into the computer and that the drivers have loaded. If you need to download new drivers for your Link-2 they can be downloaded here >> <https://www.soledigital.com.au/Link2.html>



4.1.2 Installing the FSU application

The latest FSU software can be downloaded from the Downloads tab of the following webpage: <https://soledigital.com.au/TFL300.html>

You should check this location periodically for updates.



4.1.3 Launching the application

Once the program has been installed onto your computer, double-click on the FSU program icon:



4.2 Connecting to the Device

The FSU program will automatically use the Link-2 to scan for all of the Bluetooth-enabled devices within range. This process takes approximately 10-20 seconds, and once completed will populate the program with a list of all SoleDigital devices like in the example diagram below. *TFL300* devices are

depicted by a  icon.

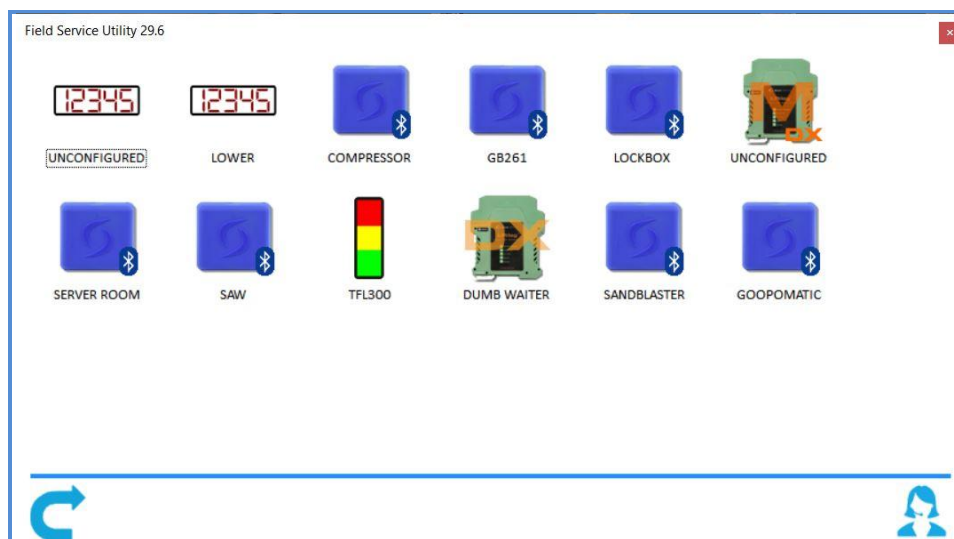

If a particular *TFL300* unit is not found, ensure it is powered up and press  to repeat the search.

*Note: The Bluetooth link between the Laptop using a Link-2 and a TFL300 has a range of approximately **100m**.*

If you require live support for any of Sole Digital products, either go to our website or open a remote support session, by pressing the  icon.

Otherwise, select the *TFL300* you wish to configure by double-clicking on the desired icon.

When you click on the *TFL300* a window will open with the settings for the unit.



4.3 Managing Firmware

Firmware updates are not always required and you should only be updating your firmware if you:

- a) Specifically want a new feature that is only available in later versions;
- b) Are experiencing a problem that has been rectified by a later version;
- c) Are experiencing a problem and need to roll back to an earlier firmware version that didn't cause the problem you are experiencing; or
- d) Have been specifically instructed to do so by your *TFL300* supplier.

To check for new firmware versions or to access old firmware versions, return to the Device Display screen and right-click the desired equipment icon. Select *'Manage Firmware'*.

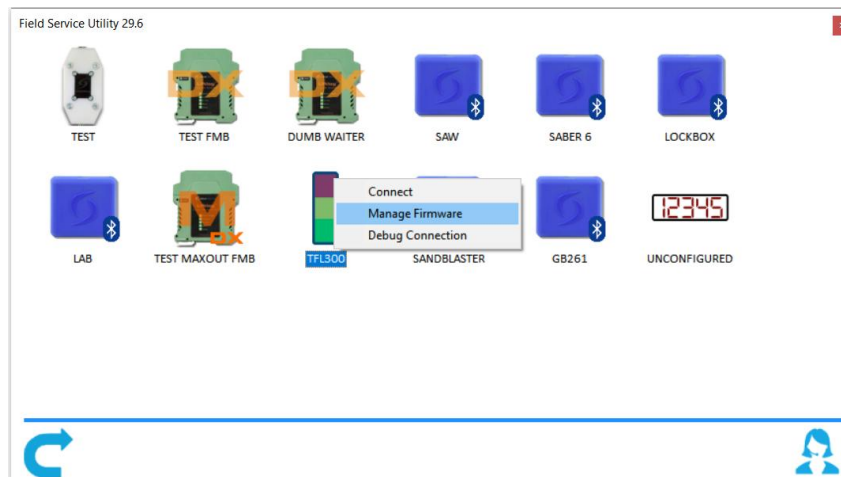

A new window will pop up and show the FSU software connecting to the device.



When this is complete, the window will show the name of the device, the current firmware version and a list of newer firmware that is available for the device.





If you need to roll back to an earlier version, check the 'Show old versions' box in the lower-left corner of the window.

Select a firmware version and then press the **<Apply firmware>** button that appears in the lower right corner of the window:

As the message states, **DO NOT switch off the TFL300 or the computer running the FSU software or remove the Link2 modem** until you are told to do so. If either device loses power then the *TFL300* will enter a recovery state when powered back up and the firmware update can be attempted again.

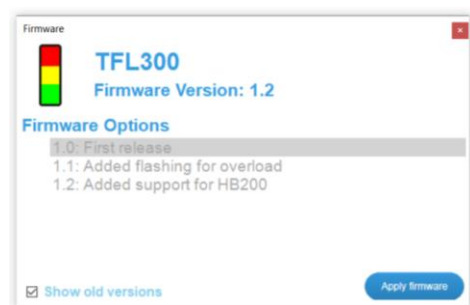



4.4 TFL300 Configuration

4.4.1 Standard TFL300 Configuration

To demonstrate a very typical calibration of a TrafficLite unit let's go back to our example graph from Part 1, a 10-tonne crane with Green until 60%, Orange until 90% and Red until 100%.

For this example, we would set the TrafficLite set points as below, with

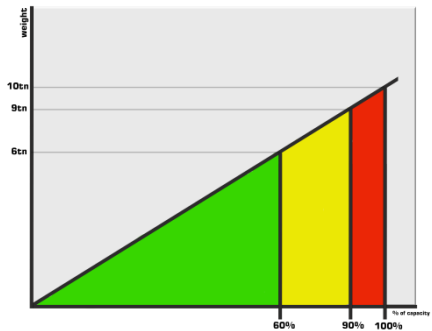

Setpoint 1 = 6000 >> Green Light On from 0kg – 6000kg

Setpoint 2 = 9000 >> Orange Light On from 6001kg – 9000kg

Setpoint 3 = 10000 >> Red Light On from 9001kg – 10000kg

Once your amounts have been set, you should wait 5-10 seconds, and then simply exit the FSU program, as the FSU will Autosave your progress every 5 seconds.

APPENDIX A: FSU SYSTEM REQUIREMENTS

The minimum requirements for operating CASWA's Field Service Utility (FSU) and Link-2 Bluetooth modem are:

- Windows 10 or later;
- One Spare USB port;
- Microsoft .NET framework 4.5;
- An internet connection.